



Yard Master 2 Series

Indoor/Outdoor Portable Projection Screen Version 2 User's Guide

Thank you for choosing the *Yard Master 2* portable projection screen! Please read through this user guide before utilizing the screen. Correct usage and maintenance will ensure a long product life

Care & Use Instructions







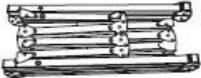

- ◆ Please be sure to distinguish between the front and back of the screen fabric when setting up the projection screen. CineWhite® (front projection) has a black backing and WraithVeil® (rear projection) is labeled front, back.
- ◆ Be sure to use the screen only during a light breeze (up to wind speeds of 7 mph); it is not meant to withstand heavy winds. **Elite Screens is not responsible for damages due to negligence resulting from misuse under weather conditions and will void your warranty.*
- ◆ Dust, dirt and scratches on the projection surface will affect the picture quality, please take note of the points below to prevent that from occurring:
 1. Do not touch the projection surface with your hands
 2. Do not write or draw on the projection surface
 3. Do not use fingers or sharp objects to point on the projection surface; this will damage the screen material.
 4. Use a soft-damp cloth to clean the projection surface; do not use chemical cleaning agents or alcohol.
 5. Use clean water when dampening the cleaning cloth and do not rub against the material to clean it.
- ◆ After using the screen, disassemble it and store it in the carrying bag provided.
- ◆ To avoid damage and injury, the screen should only be operated by adults.

Product Description

Design: The aluminum frame is designed to be light weight and easily operated making it easy to carry, assemble and disassemble.

Screen Fabric: The screen fabric is attached to the rectangular frame and held in place by several press studs, which ensure an evenly stretched and flat surface. The CineWhite® (front projection) and WraithVeil® (rear projection) screen materials are durable and can be folded many times without causing damage or distortion to the surface.

Parts Diagram

<p>A. Folding frame x1</p> 	<p>B. Left and right folding legs x2</p> 	<p>C. Screen material bag x1</p> 
<p>D. Projection screen material x1</p> 	<p>E. Knob screw x2 (small) x2 (Large)</p> 	<p>F. Eyebolt x2</p> 
<p>G. Rope x2</p> 	<p>H. Carrying Bag x1</p> 	<p>I. Stake x4</p> 

Note: The parts list above is subject to change without notice.

Correct usage of the projection screen will ensure better viewing results.

For front projection (CineWhite®), assemble and view the screen as indicated in Fig.1.

For rear projection (WraithVeil®), assemble and view the screen as indicated in Fig.2.

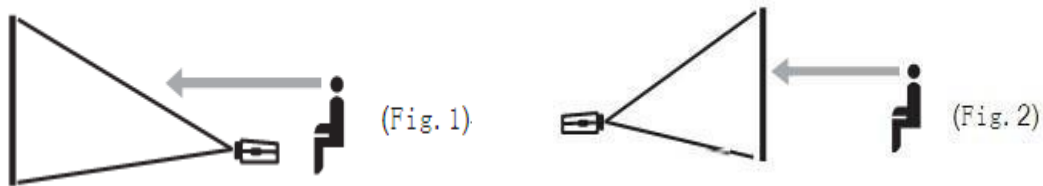

Frame Assembly and Screen Material Attachment

1. Take the *folding frame (A)* out of the *carrying bag (H)* and place it on a flat surface. Unfold the longer sections first as shown in Fig.3-4.

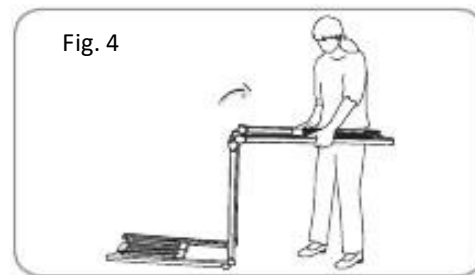
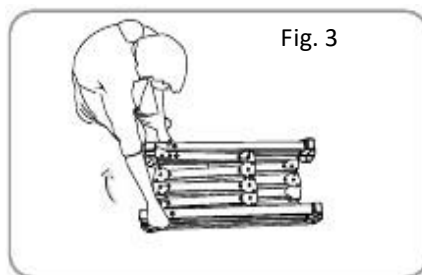

2. Unfold the frame until the latch on the hinge "clicks" into place. Repeat the procedure for the shorter sections. (Fig. 5-6)

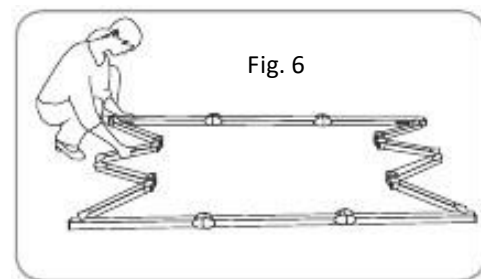
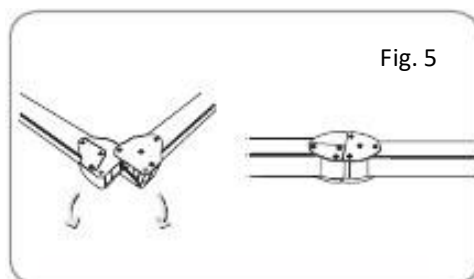

3. Make sure all 4 corners of the frame are at a 90° angle and the hinged support bar is straight and not bending. (Fig. 7-9)

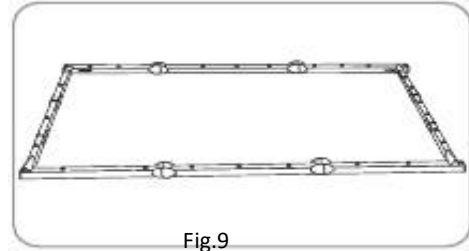
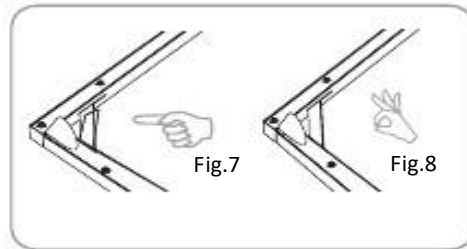

4. Insert the frame *legs* (*B*) into the openings located at the left and right bottom sides of the *folding frame* (*A*). Secure them by fastening the *knob screw* (*E*) into the adjacent hole. The added support behind the leg will be unfolded in a later step.

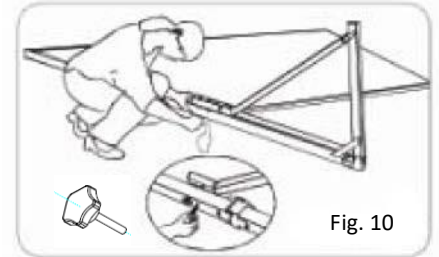

5. Next, screw the *eyebolts* (*F*) into the openings located at the top of the frame (Fig.10).

6. Take the *screen material* (*D*) out of the *screen material bag* (*C*) and align the corners of the screen material with the inside corners of the frame. Unfold as shown in the diagram (Fig.11-12).

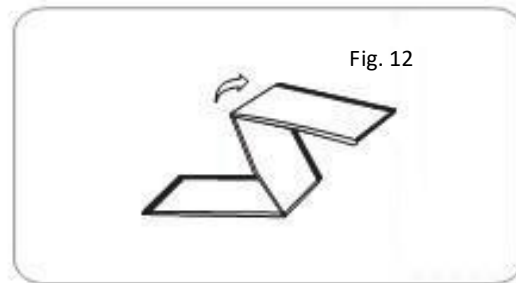
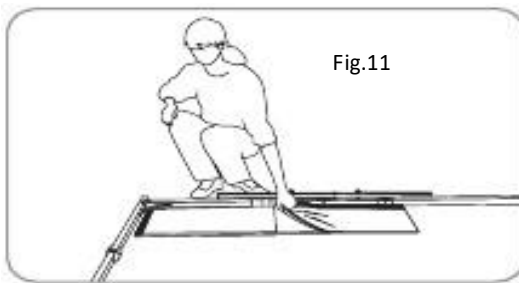

7. Once the *screen material* (*D*) is fully extended, secure the material by snapping the buttons onto the frame studs as shown in Fig. 13-15. Fasten the buttons in the following order AB→CD→EF→GH.

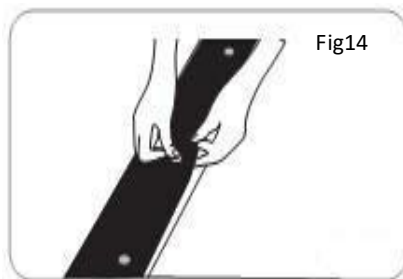
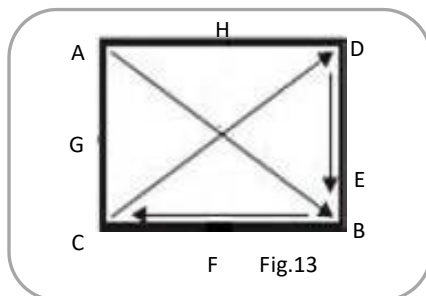

8. If you have a bit of difficulty attaching the material, try this alternate option. Unlatch the sides of the frame, then carefully place the **material (D)** over it. Begin attaching the material by snapping the buttons on all four corners and horizontal sides of the frame.



9. Carefully latch the sides of the frame so it's completely unfolded, then snap the rest of the buttons on the vertical sides of the material.

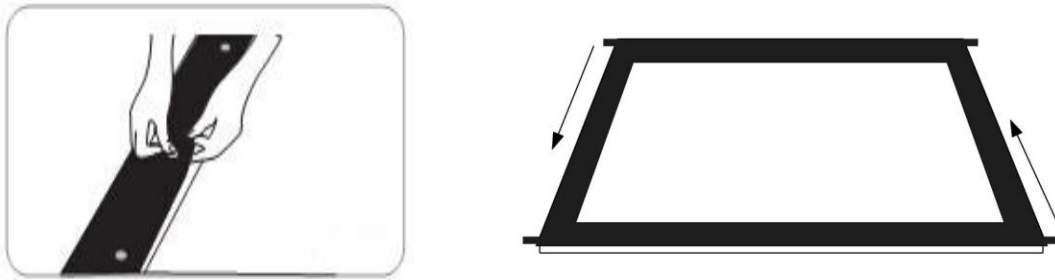

10. Tie 4 pieces of **rope** (2 on the left and 2 on the right) to the **eyebolts (F)** that are located at the top of the frame. Next, lift the screen up while simultaneously opening the frame legs. Two people are needed for this step. Fig.16-17

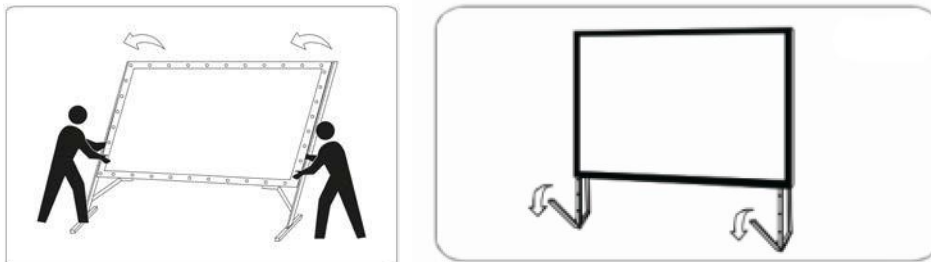

11. Next, carefully unfold the extra support leg behind the leg and attach it securely using a **knob screw (E)**.

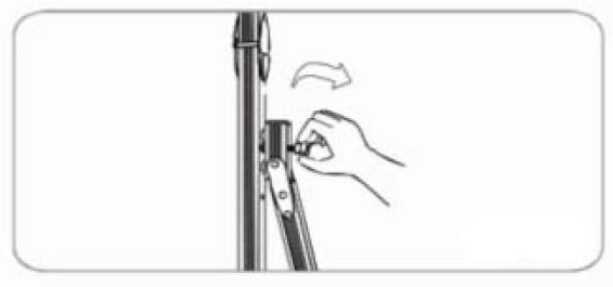
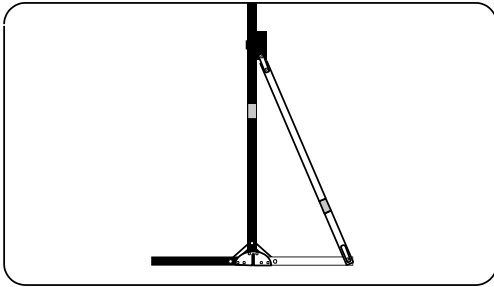

12. To secure the frame, place a **stake (I)** into each hole located on the frame footing, and hammer it into the ground. Finally, tie the 4 **ropes (G)** to the stakes to prevent the screen from tilting or falling over. As shown in fig.18.

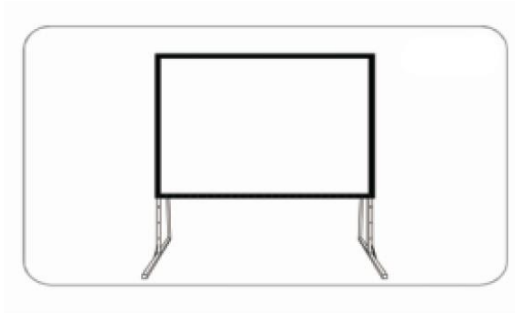

Screen Disassembly

1. Remove **ropes (G)** and **stakes (I)** from the ground.
2. Unlatch the hinged support bars on front side of each leg so that it is bent and fold that half of the legs up for the next step.
3. Slowly lower the screen to the ground (towards the closed legs).
Two people are needed for this step.

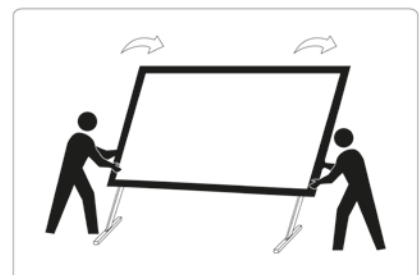

4. Loosen and remove the ropes, **knob screws (E)** and **eyebolts (F)** from each leg.
5. Unlatch the hinged support bars and fold down other half of legs

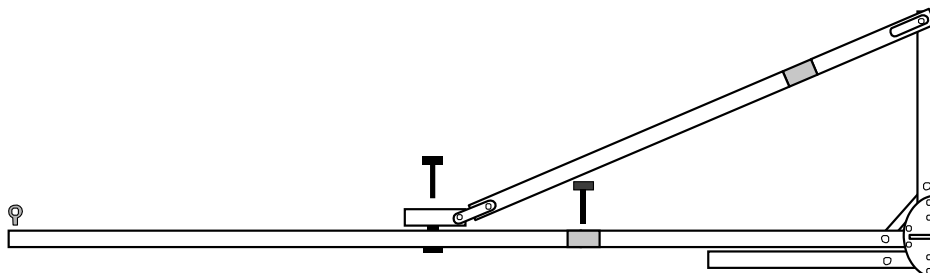

6. Remove the frame *legs (B)* from the *folding frame (A)*.

7. Detach the *screen material (D)* from the *folding frame (A)* by carefully unsnapping each button as shown.



8. Fold *screen material (D)* in half, folding the bottom of the screen towards the top. Then, fold in half again in the same way. Lastly, fold the material into thirds to condense the length, see Fig. 19 – 21.

*If you prefer to roll the material, instead of folding into thirds, roll from one end to the other after folding in half twice.

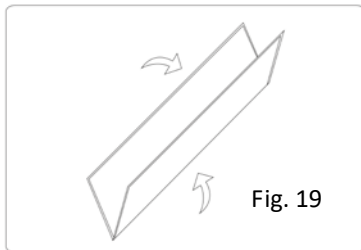

Fig. 19

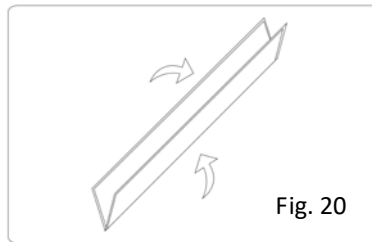

Fig. 20

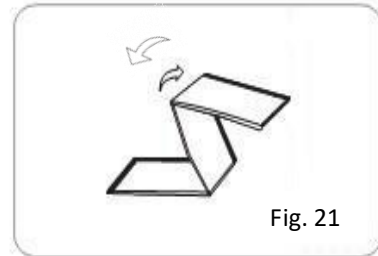
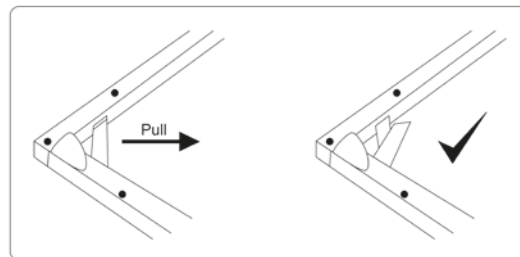
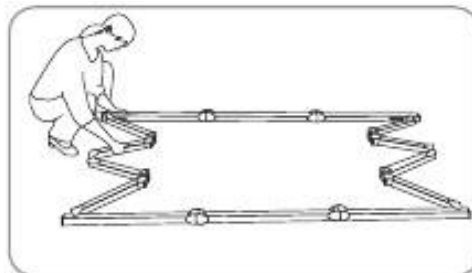

Fig. 21

9. Unlatch the hinged support bars in each corner of the *folding frame (A)*.



10. Press in the silver locking buttons, near the folding joints, and slowly gather the sides of the folding frame.



11. Again, press in the silver locking buttons. Then, pick up one end of the folding frame, and walk it to the other end, folding the longer sections into thirds.

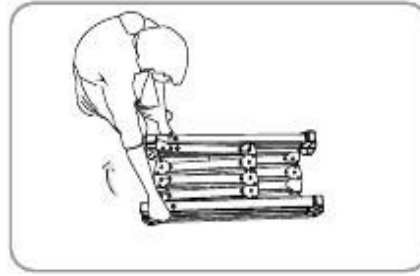

12. Store the screen in the provided *carrying bag (h)*. Be sure to place folding frame, legs, and smaller parts into the carrying bag first and place the material on top to keep material from creasing or tearing.

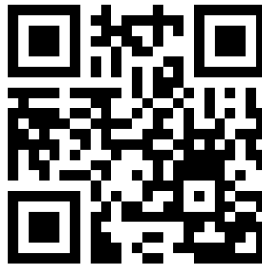

Scan the QR code to watch Assembly video

For a local Elite Screens contact or Technical Support, please visit
www.elitescreens.com